

Speculations Regarding Orbital Stressing Mechanisms

An Edited Collection of November, 1997
Vortex Posts by Horace Heffner

One reason bound electron capture (E.C.) rates are small is the fact that the probability that electrons occupy the nucleus is small. This is due primarily to the quantized mechanics of the atom. After all, if it weren't for quantum mechanics the electrons would simply fall into the nucleus and all matter would collapse. Typically the net translational force between the nucleus and the electron cloud is zero. The nucleus occupies a neutral position in the electron cloud, called the center of charge of the cloud. This center of charge can be displaced, however. This displacement can be accomplished by applying an electric field, for example. In that case the nucleus and center of charge find a new equilibrium point, where the force of external electric field is balanced with the force from the center of charge.

If a sufficient force can be exerted on the nucleus relative to the electron cloud, the center of charge can also be made to displace from the nucleus. In this case an electric field is generated by the atom. Such a displacement can be generated by gravitational or inertial forces. Electrostatic fields can be generated by use of centrifuges using this principle, for example.

The main thought here is that when the center of charge is displaced, the nucleus should then occupy a volume of the electron probability distribution, ψ^2 , having a much larger value than the neutral zone volume probability. If this is the case, then the probability of electron capture should be measurably higher.

Here are the basic practical methods of displacing the nucleus on a continual basis in order to affect the rate of electron capture:

- (a) Apply a strong electrostatic force
- (b) Use centrifugal force by placing sample in a centrifuge or accelerating it
- (c) Rattle the sample with ultrasonics
- (d) Rattle the sample with electrostatics
- (e) Rattle the sample with electromagnetics
- (f) A hybrid of the above

Speculations Regarding Orbital Stressing Mechanisms

An Edited Collection of November, 1997
Vortex Posts by Horace Heffner

Note that (a) may be a clue as to why the Barker experiment, increasing decay rates of radio isotopes by placing them on the edge of a charged empty sphere, may work.

Of further interest may be the fact that at the interface, the layer at the surface of an electrode in an electrolysis cell, enormous electrostatic field gradients occur, even though the total voltage differential is small. However, there are means for greatly increasing the voltage differential and field gradient, so maybe these should be explored further with the aim of creating electron capture [or electron catalysis] and energy production or transmutation effects.

As suggested by Frank Stenger (vortex posting 11:25 PM 11/18/97), a suitable microwave wave guide arrangement could provide a rotation rate of 2400 MHz, or 144,000,000,000 rpm. However, without some way to spin up to that angular velocity, it is unlikely the nuclei could ever catch up. There is also the problem of heat generated.

One possibility to explore is making the whole electron lattice vibrate in synch, though the amplitude would be small and the frequency very fast. The sample might be suspended in a vacuum between fibers, or magnetically suspended. (In this case the lattice moves while the nuclei remain in approximately constant positions.)

Other possible problems are radiation, and resistance heating, due to the lattice electrons vibrating back and forth.

It does seem that the electron capture rate should go up measurably though, even if the sample is only shaken acoustically, or placed in a strong gradient. The combination of the two is even better. So, if that can work, it seems like spinning at 144,000,000,000 rpm, if it is possible, should work well. (An electrostatic method to accelerate the electrons up to speed so a similar microwave approach can take over is shown in Fig. 1)

However, since the nuclei are 1000 times heavier, assuming the idea can work at all, the electron cages are, for the most part, going to move around the nuclei as a single lattice unit. Thus the amount of mass involved in motion is small, which is good for creating higher speed action. The hard part, it seems, is keeping the lattice electron motion uniform throughout the sample, thus avoiding heat loss.

Speculations Regarding Orbital Stressing Mechanisms

An Edited Collection of November, 1997
Vortex Posts by Horace Heffner

To achieve (f) above, a hybrid approach, one method may be to get the nucleus to slide around inside the cloud like a piece of ice inside a basketball, thus generating centrifugal force to displace the nucleus relative to the cloud. Fig. 1 is a design to achieve this.

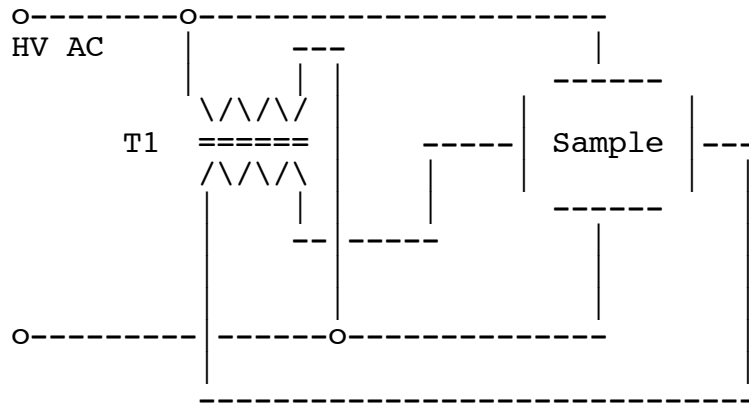

Fig. 1

Note that T1 may be air core or replaced with other circuitry which can maintain the horizontal and vertical plates 90 degrees out of phase. The main objective is to create a rotating electrostatic field (that possibly initially increases in frequency) that drags the nuclei along around in circles inside their atoms. One interesting fact of this approach is that there appears to be no resonant frequency involved, except secondarily. If the nucleus did not slide around the cloud uniformly, due to heat effects for example, then the rotational energy could be diverted into the nucleus rattling around bouncing off the walls, an effect which would initially have its own resonant frequency, depending on the atom, and eventually result in heat. Placing the atom in a strong magnetic field would at least tend to divert such rattling around into a plane perpendicular to the magnetic field, and provide a chance for the nucleus to come back into synch. Combining these thoughts, such a device might best operate at the resonant frequency for the atom, with a strong magnetic field coming out of the page in the drawing above.

Some things are bothersome about the fact E.C. does not occur where conservation of

Speculations Regarding Orbital Stressing Mechanisms

An Edited Collection of November, 1997
Vortex Posts by Horace Heffner

energy (C of E) forbids it, and even some cases where it does not. What are the mechanics of this conservation? If an e and p are within range of operation of the weak force, then what mechanism prevents the reaction? It seems the reaction might take place within the boundaries of the time in which borrowed energy is available from the uncertainty principle, but that would be an extremely short period of time - and there is the problem of that escaping neutrino. If any sizable delay of the electron inside the nucleus can be made to exist, especially in hydrogen, then a possible mechanism for permitting the nucleus to tunnel through a coulomb barrier into another nucleus then also exists.

More significantly, if some portion of a nucleus can undergo an E.C., which then makes the nucleus unstable with respect to the two portions, the E.C. capturing portion, and the remaining portion, then fission might be produced by that electron capture. If E.C. can result in fission, then there is an open question as to whether the energy of the fission might be used to negate the impossibility of the reaction due to C of E.

It seems unfortunate that the heavy isotopes subject to E.C., regardless of other decay pathways involved, with few exceptions, have very short half lives, and thus are not a problem for remediation. (Some exceptions are ^{149}Eu ^{150}Eu ^{152}Eu , ^{157}Tb , ^{158}Tb , ^{163}Ho , ^{173}Lu , ^{174}Lu , ^{193}Pt , ^{194}Hg , ^{204}Tl , ^{202}Pb , ^{205}Pb , ^{207}Bi and ^{208}Bi .) This makes one wonder if possibly some alpha decays, or other decay modes, are actually precipitated by an unseen initial E.C.. The E.C. could be readily missed if any of the fission products resulted in short half life beta decays? It seems strange that the other long half life heavy nuclei, within the above isotope range between ^{149}Eu and ^{205}Pb , have no E.C. pathway.

This is grasping at straws to say electrons can have a role in fission processes, but on the other hand it could explain a few things if electrons *are* involved in the fission process. E.C., its mechanisms per se, need not even be an issue. The issue really is more whether bound electrons may be involved in an energy exchange with the nucleus that triggers nuclear decays, especially alpha decay, in long half life heavy elements. However, the nice thing about studying E.C.s from the point of view of stimulating the atom by kinetics, heat, or EM, is that it seems there is a direct bearing on the issue by the increased presence of the electrons in the nucleus. There is a direct bearing on the issue due to the increased *energy* of the electrons being in the nucleus as well, and maybe that is more to the point when it comes to

Speculations Regarding Orbital Stressing Mechanisms

An Edited Collection of November, 1997
Vortex Posts by Horace Heffner

remediation.

By vibrating electron shells, or a lattice as a whole, by electromagnetic stimulation, or by kinetic stimulation, the displacement of the center of charge from the nucleus should also increase the probability of orbital electrons being within the nucleus. Orbital electron(s) that enter within a nucleus carry a significant amount of energy. If a nucleus is unstable, and is suddenly endowed with the externally supplied energy of the electron interacting with the nucleus, via either the weak force or the EM force, it seems such a presence of such electrons could push the nuclear energy over a threshold and trigger a nuclear disintegration. This is an implication that half lives might be reduced by kinetic or EM stimulation, and thus has a bearing on nuclear remediation. Further, then, is the question: have bound electrons played a role in half lives all along without detection?

By the orbital stressing hypothesis, decay times should decrease with increased heat. However, heat would be a very ineffective way to accomplish decay acceleration, and results would be difficult to measure. The reason for this is that an average kinetic energy of only $1 \text{ eV} = 11,600 \text{ Deg. K}$. Further, atoms in a high state of thermal excitement would not have their nuclei exposed to maximum electron density for the full cycle either. For this reason it is more desirable to use an electrostatic method vs a thermal method, preferably in a steady state condition, to achieve higher electron concentrations in the nucleus. It seems to me the trick is to create strong electrostatic (and possibly magnetic) conditions without creating heat. One means to think about for achieving this may be to oscillate an entire electron matrix together simultaneously in phase. Another method is simply to attempt to maximize an electrostatic field gradient. Here is a prescription for achieving enhanced decay rates using a static field gradient:

- (1) Use an electrolytic cell with the reactant dissolved in the electrolyte
- (2) Pump the electrolyte through the cell slowly and use primarily diffusion of the cell to carry the reactant the final small distance to the electrode insulator surface and to carry away byproducts from that surface.
- (3) Use electrodes covered with the highest dielectric strength material

Speculations Regarding Orbital Stressing Mechanisms

An Edited Collection of November, 1997
Vortex Posts by Horace Heffner

available.

- (4) For best energy utilization use a DC cell with small or no current. The electrodes are fully insulated, so there is no current with the exception of leakage.
- (5) Use the thinnest possible coating that provides a reliable uniformity of breakdown potential in the environment
- (6) Operate the cell at the highest voltage that does not break down the electrode surface insulation.
- (7) The distance between electrodes has no effect on the gradient achieved at the insulator surface, but still should be minimized in order to achieve maximum effect per cell volume [note - periodic field reversal may be required to prevent charge accumulation within the insulator surface and thus reduction of the surface gradient.]
- (8) When the above is achieved the volume of material that can be processed per unit time is then just a linear function of area, so electrode area per cell volume should be maximized.
- (9) When the above is achieved, additional stimulation from heat, sound, etc., to the extent it does not affect any of the above adversely, can only add to the effect. However, the benefits should be minimal in comparison to the field gradient method.

The application of the basic practical methods of displacing the nucleus, and combinations of them, apply to a wide range of purported energy creating devices, and in particular, to the Mills hydrino creating devices.

There should not be much tolerance, other than due to calculation accuracy, on the 27.21 eV hydrino formation energy calculated by Mills and Kneizys. Such a formation is quantized. Unlike bonds, which deform and have a range of quantized energies, hydrino formation should be limited to strictly (or very closely) the orbital energy values, i.e. the series of values corresponding to the various quantum states $1/n$. Also, given that there are many $1/n$ states, there should be many more

Speculations Regarding Orbital Stressing Mechanisms

An Edited Collection of November, 1997
Vortex Posts by Horace Heffner

formation energies besides 27.21 eV.

An interesting method to give rise to a wider range of energies of formation, even if only one quantum state, n fixed, is available for hydrino formation. It is the application of a very strong magnetic field to the hydrino forming environment. This would deform the hydrino orbital and, if sufficient magnetic flux is available, deform the hydrino electron orbital into a Rydberg style orbital, extending parts out where orbitals become fuzzy, lose their quantized values, and where orbital hops result in randomized and continuous photon energy distributions. If emission distribution changes then so does the energy absorption distribution. It may even be possible to detect a hydrino in a sufficiently strong magnetic field, assuming hydrinos exist, of course, which would provide a good confirmation of this idea, as well as of the hydrino theory. More importantly, it may help provide a far more robust hydrino creation method, by greatly broadening the hydrino formation energy tolerance.

Some possible candidate reactions for hydrino formation listed by Mills (Mills and Kneizys, Fusion Technology, Vol 20, pp 65-81,1991) and Strojny (vortex post of 11/12/97, which included prior reference) are:

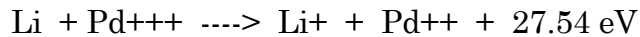
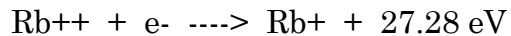
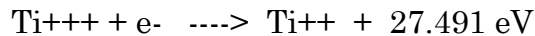
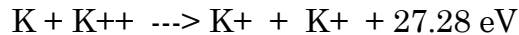

Note that if the range of energies for hydrino formation can be extended sufficiently, other prospects emerge:

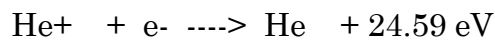
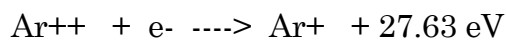
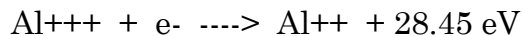

Speculations Regarding Orbital Stressing Mechanisms

An Edited Collection of November, 1997
Vortex Posts by Horace Heffner

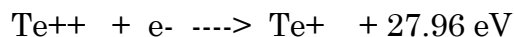
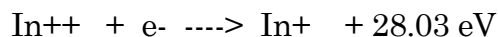
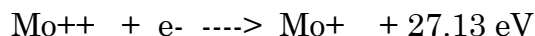
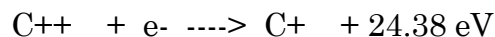

Note that the distortion of the standard electron orbital of the catalyst electron into a Rydberg orbital may be sufficient to catalyze hydrino formation. No distortion of the hydrino orbital is required, though it is clear some distortion of even a hydrino orbital must occur in a sufficiently strong magnetic field. The combination of distortions may be sufficient to bridge the energy gap for hydrino formation catalysis, especially in the case of Ar.

All we need do is evacuate and then charge up a cell with Ar and H, place in strong B, and start an electrical discharge, preferably using Mo, Ti, or Al electrodes. Mo is better for heat characteristics. It is speculated that this will generate lots of hydrinos.

One issue is the best way to manage hydrinos so they don't get away, and so they combine to make energy. One way may be to enclose the discharge tube in a large water tank. Those hydrinos that leak through discharge tube walls then get absorbed in the H₂O. The H in the H₂O should act as a moderator, thus permitting a hydrino buildup in the region of the discharge tube.

Unlike as portrayed in the Bohr and Mills standard theories, Rydberg orbitals are not simple orbitals, but very complex geometrical shapes involving multiple circumnavigations of the nucleus per orbital, at least as seen in some two dimensional projections of the Rydberg orbital. It makes some sense that such orbitals might be viewed as folded into an overtone harmonic of a Bohr orbital and it may be that (another wild conjecture) the creation of a Rydberg style orbital might be used as a preliminary step in the creation of a hydrino. which itself could be viewed as a folded harmonic of a Bohr orbital.

Speculations Regarding Orbital Stressing Mechanisms

An Edited Collection of November, 1997
Vortex Posts by Horace Heffner

Of further interest, and relevant to achieving method (f) above, the hybrid approach, is the fact that electrons in Rydberg orbitals, in addition to being driven out into non-quantized fringe areas, thus producing fuzzy spectra, are also driven in deep close to the nucleus. Thus, the near nucleus electron density is increased in a strong magnetic field. A combination of strong magnetic field combined with the increase of near nucleus density provided in Rydberg orbitals may provide significant changes in rates and other electron-nuclear interactions (e.g. see my Partial Orbital Hypothesis posted on vortex earlier) - all with no energy expenditure, only the cost of establishing the static fields. The use of a strong magnetic field combined with a material sample adjacent to a strong dielectric electrostatically stressed to the maximum, has the advantage of eliminating all ongoing input energy, thus greatly simplifying calorimetry and reducing signal/noise ratio. Of course, the big question remains - does it work?